

CarryVac 3

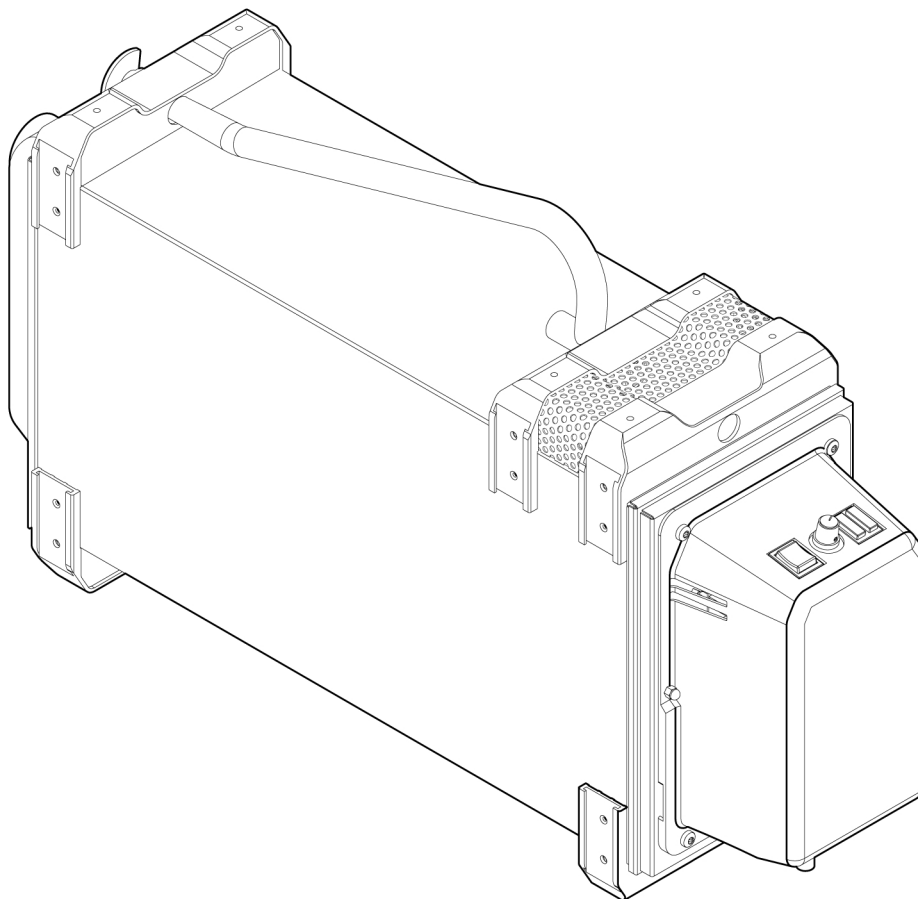

Instruction manual **Original instructions**



EU DECLARATION OF CONFORMITY

According to
The Machinery Directive 2006/42/EC, entering into force 17 May 2006
The EMC Directive 2014/30/EU, entering into force 20 April 2016
The RoHS Directive 2011/65/EU, entering into force 2 January 2013

Type of equipment
Fume extractor

Type designation
Carry Vac 3 230V 0700 003 890
Carry Vac 3 230V Hose 0700 003 893
Connection

Brand name or trademark
ESAB

Manufacturer or his authorized representative established within the EEA
Name, address, and telephone No:
ESAB AB
Lindholmsallén 9, Box 8004, SE-402 77 Göteborg, Sweden
Phone: +46 31 50 90 00, Fax: +46 31 50 92 22

The following harmonized standards in force within the EEA has been used in the design:

EN ISO 21904-1:2020, EN ISO 12100:2010, EN ISO 20607:2019
EN 61000-6-2:2019, EN 61000-6-4:2019
EN 61000-3-3:2013, EN 60204-1:2018

Additional Information:
Restrictive use, Class A equipment, intended for use in location other than residential.

By signing this document, the undersigned declares as manufacturer, or the manufacturer's authorized representative established within the EEA, that the equipment in question complies with the safety requirements stated above.

Date

Signature

Position

2023-05-22

Bartosz Kutarba

Bartosz Kutarba

Global Director Light Industrial
Products Welding and Plasma

CE 2023



UK DECLARATION OF CONFORMITY

According to:

- Electric Equipment (Safety) Regulations 2016;
- Electromagnetic Compatibility Regulations 2016;
- The Restriction of the Use of Certain Hazardous Substances in Electrical and Electronic Equipment Regulations 2012 (as amended)

Type of equipment

Fume extractor

Type designation

CarryVac 3 230V

0700 003 891

Brand name or trademark

ESAB

Manufacturer or his authorised representative established within United Kingdom

ESAB Group (UK) Ltd,
322 High Holborn, London, WC1V 7PB, United Kingdom
www.esab.co.uk

The following British Standards and Instruments in force within the United Kingdom has been used in the design:

- BS EN ISO 21904:2020	Health and safety in welding and allied processes – Equipment for capture and separation of welding fume – Part 1: General requirements.
- BS EN ISO 12100:2010	Safety of machinery – General principles for design – Risk assessment and risk reduction.
- BS EN ISO 20607:2019	Safety of machinery – Instruction handbook
- BS EN ISO 61000-6-2:2019	EN 61000-6-4:2019
- BS EN 61000-3-3:2013	EN 60204-1:2018

Additional Information:

Restrictive use, Class A equipment, intended for use in locations other than residential.

By signing this document, the undersigned declares as manufacturer, or the manufacturer's authorised representative established within the UK, that the equipment in question complies with the safety and environmental requirements stated above.



Bartosz Kutarba

Bartosz Kutarba
Global Director Light Industrial Products
Welding and Plasma
Date: 2023-05-22

David Todd

David Todd
Commercial Director,
ESAB Group UK & Ireland
Date: 2023-06-01

TABLE OF CONTENTS

1	SAFETY	5
1.1	Meaning of symbols	5
1.2	Safety precautions	5
1.3	California proposition 65 warning	8
2	INTRODUCTION	9
2.1	Equipment	9
3	TECHNICAL DATA	10
4	OPERATION	11
4.1	Connections and control devices	11
4.2	Manual mode	12
4.3	Automatic mode	12
4.4	Adjusting the suction power	12
4.4.1	Using the unit with a Nozzle (N1-N3)	12
4.4.2	Using the unit with a fume extraction torch (T1-T8)	13
4.5	Status lights, Warnings and Alarms	13
5	MAINTENANCE	14
5.1	Cleaning the filter	14
5.2	Opening the coarse separator	16
6	TROUBLESHOOTING	18
7	ORDERING SPARE PARTS	19
	WIRING DIAGRAM	20
	ORDERING NUMBERS	21
	SPARE PARTS LIST	22
	REPLACING THE CIRCUIT BOARD	24
	REPLACING THE MOTOR	26
	REPLACING THE SPARK FILTER	28
	ACCESSORIES	30

1 SAFETY

1.1 Meaning of symbols

As used throughout this manual: Means Attention! Be Alert!



DANGER!

Means immediate hazards which, if not avoided, will result in immediate, serious personal injury or loss of life.



WARNING!

Means potential hazards which could result in personal injury or loss of life.



CAUTION!

Means hazards which could result in minor personal injury.



WARNING!

Before use, read and understand the instruction manual and follow all labels, employer's safety practices and Safety Data Sheets (SDSs).



1.2 Safety precautions

Users of ESAB equipment have the ultimate responsibility for ensuring that anyone who works on or near the equipment observes all the relevant safety precautions. Safety precautions must meet the requirements that apply to this type of equipment. The following recommendations should be observed in addition to the standard regulations that apply to the workplace.

All work must be carried out by trained personnel well-acquainted with the operation of the equipment. Incorrect operation of the equipment may lead to hazardous situations which can result in injury to the operator and damage to the equipment.

1. Anyone who uses the equipment must be familiar with:
 - its operation
 - location of emergency stops
 - its function
 - relevant safety precautions
 - welding and cutting or other applicable operation of the equipment
2. The operator must ensure that:
 - no unauthorised person is stationed within the working area of the equipment when it is started up
 - no-one is unprotected when the arc is struck or work is started with the equipment
3. The workplace must:
 - be suitable for the purpose
 - be free from drafts
4. Personal safety equipment:
 - Always wear recommended personal safety equipment, such as safety glasses, flame-proof clothing, safety gloves
 - Do not wear loose-fitting items, such as scarves, bracelets, rings, etc., which could become trapped or cause burns

5. General precautions:

- Make sure the return cable is connected securely
- Work on high voltage equipment **may only be carried out by a qualified electrician**
- Appropriate fire extinguishing equipment must be clearly marked and close at hand
- Lubrication and maintenance must **not** be carried out on the equipment during operation

If equipped with ESAB cooler

Use ESAB approved coolant only. Non-approved coolant might damage the equipment and jeopardize product safety. In case of such damage, all warranty undertakings from ESAB cease to apply.

For ordering information, see the "ACCESSORIES" chapter in the instruction manual.

**WARNING!**

Arc welding and cutting can be injurious to yourself and others. Take precautions when welding and cutting.

**ELECTRIC SHOCK - Can kill**

- Install and ground the unit in accordance with instruction manual.
- Do not touch live electrical parts or electrodes with bare skin, wet gloves or wet clothing.
- Insulate yourself from work and ground.
- Ensure your working position is safe

**ELECTRIC AND MAGNETIC FIELDS - Can be dangerous to health**

- Welders having pacemakers should consult their physician before welding. EMF may interfere with some pacemakers.
- Exposure to EMF may have other health effects which are unknown.
- Welders should use the following procedures to minimize exposure to EMF:
 - Route the electrode and work cables together on the same side of your body. Secure them with tape when possible. Do not place your body between the torch and work cables. Never coil the torch or work cable around your body. Keep welding power source and cables as far away from your body as possible.
 - Connect the work cable to the workpiece as close as possible to the area being welded.

**FUMES AND GASES - Can be dangerous to health**

- Keep your head out of the fumes.
- Use ventilation, extraction at the arc, or both, to take fumes and gases away from your breathing zone and the general area.

**ARC RAYS - Can injure eyes and burn skin**

- Protect your eyes and body. Use the correct welding screen and filter lens and wear protective clothing.
- Protect bystanders with suitable screens or curtains.

**NOISE - Excessive noise can damage hearing**

Protect your ears. Use earmuffs or other hearing protection.

MOVING PARTS - Can cause injuries



- Keep all doors, panels, guards, and covers closed and securely in place.
- Have only qualified people remove covers for maintenance and troubleshooting as necessary.



- Keep hands, hair, loose clothing and tools away from moving parts.
- Reinstall panels or covers and close doors when service is finished and before starting the unit.

FIRE HAZARD



- Sparks (spatter) can cause fire. Make sure that there are no inflammable materials nearby.
- Do not use on closed containers.

HOT SURFACE - Parts can burn



- Do not touch parts bare handed.
- Allow cooling period before working on equipment.
- To handle hot parts, use proper tools and/or insulated welding gloves to prevent burns.



CAUTION!

This product is solely intended for arc welding.



WARNING!

Do not use the power source for thawing frozen pipes.



CAUTION!

Class A equipment is not intended for use in residential locations where the electrical power is provided by the public low-voltage supply system. There may be potential difficulties in ensuring electromagnetic compatibility of class A equipment in those locations, due to conducted as well as radiated disturbances.

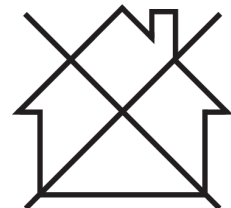

NOTE!

Dispose of electronic equipment at the recycling facility!

In observance of European Directive 2012/19/EC on Waste Electrical and Electronic Equipment and its implementation in accordance with national law, electrical and/or electronic equipment that has reached the end of its life must be disposed of at a recycling facility.

As the person responsible for the equipment, it is your responsibility to obtain information on approved collection stations.

For further information contact the nearest ESAB dealer.

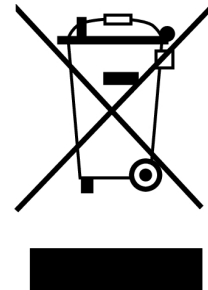

ESAB has an assortment of welding accessories and personal protection equipment for purchase. For ordering information contact your local ESAB dealer or visit us on our website.

1.3 California proposition 65 warning



WARNING!

Welding or cutting equipment produces fumes or gases which contain chemicals known in the State of California to cause birth defects and, in some cases, cancer. (California Health & Safety Code Section 25249.5 et seq.)



WARNING!

This product can expose you to chemicals including lead, which are known to the state of California to cause cancer and birth defects or other reproductive harm. Wash hands after use.

For more information, go to www.P65Warnings.ca.gov.

2 INTRODUCTION

The **CarryVac 3** is a portable welding filter that filters out pollutants such as fumes and dust, class W3 (non-alloy steel to high alloy steel with nickel and chromium > 30%).

ESAB accessories for the product can be found in the "ACCESSORIES" chapter of this manual.

2.1 Equipment

The CarryVac 3 is supplied with:

- instruction manual

3 TECHNICAL DATA

CarryVac 3	
Dimensions	800 × 406 × 222 mm
Noise level at 100% motor power	79 dB(A) at 1m, ISO 11201
Weight	14.8 kg (32.6 lb)
Storage temperature	-20 to +60 °C
Operating temperature	0 to +35 °C
Max. altitude	1000 m above sea level
Max. relative humidity (both storage and operation)	95%
Voltage	110/220–240 V AC
Power	1250/1300 W (1.7 hp)
Max. vacuum generated by the motor	25 kPa (100 in. w.g.)
Max. vacuum at hose connection	18 kPa (72 in. w.g.)
Capacity with 2.5 m hose	180 m ³ /h (106 cfm)
Filter area	5.3 m ²
Filtration efficiency	>99% (ISO 21904-2) F9 (EN779) MERV 14 (ASHRAE 52.2)

4 OPERATION

General safety regulations for handling the equipment can be found in the "SAFETY" chapter of this manual. Read it through before you start using the equipment!



NOTE!

When moving the equipment use intended handle. Never pull the cables.



WARNING!

Electric shock! Do not touch the workpiece or the welding head during operation!

4.1 Connections and control devices

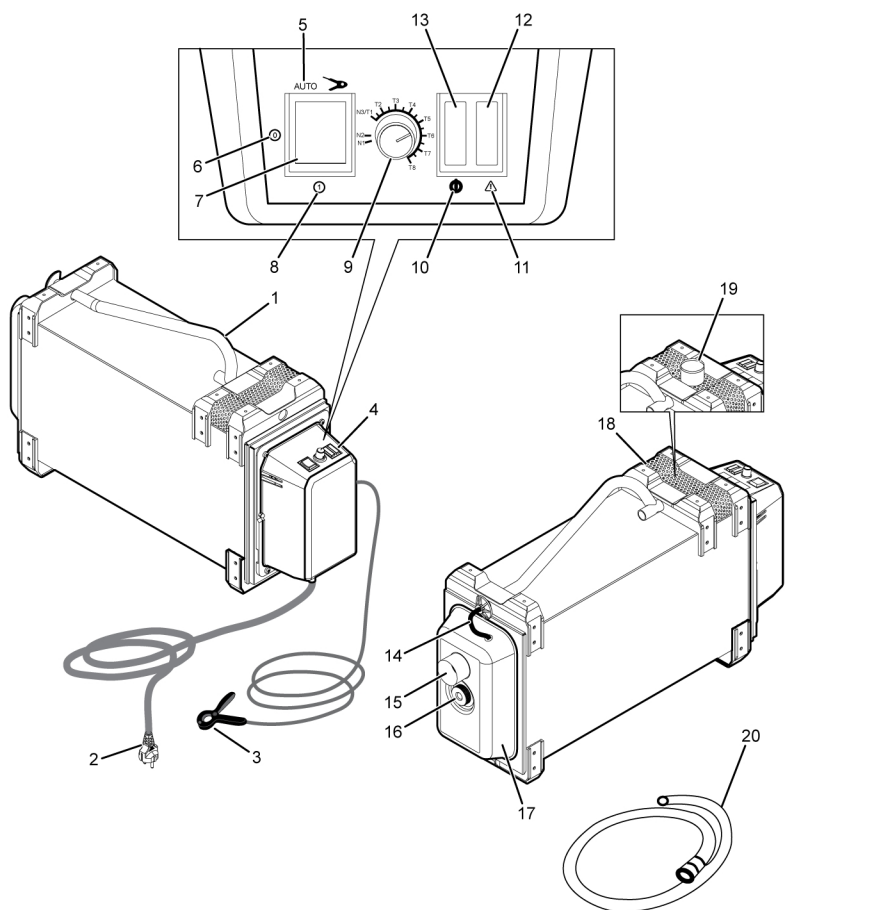

1. Handle/lock
2. Mains cable
3. Sensor clamp
4. Suction settings
5. AUTO position
6. OFF position
7. Mains switch
8. ON position
9. Knob for suction power
10. Standby

11. Warning and Alarm
12. Orange light
13. Green light
14. Filter indicator hose
15. Hose connection
16. Locking screw
17. Coarse separator
18. Exhaust
19. Exhaust, hose connection (optional)
20. Suction hose

1. Connect the suction hose (20) to the inlet hose connection (15).
2. Connect the other end of the suction hose to the extraction point (nozzle/hood).
3. Optional, connect the sensor clamp to the return ground wire of the welding equipment.
4. Optional, connect the exhaust hose to the exhaust hose connection (19).

**NOTE!**

Do not block exhaust (18) and (19).

4.2 Manual mode

Set the mains switch (7) to position ON (8).

The unit will now work continuously. A fixed green light (13) indicates that the unit is in operation.

4.3 Automatic mode

- 1) Place the welding cable or return cable in the current sensor clamp (3).
- 2) Set the main switch (7) to the AUTO position (5). The green light (13) will flash, indicating that the unit is in standby mode.
- 3) The unit will start when the welding arc is struck and return to standby 10 seconds after the arc is broken.

4.4 Adjusting the suction power

**NOTE!**

The scale of the knob (9) corresponds to a pressure setpoint, not motor speed. Therefore, the full motor speed can be reached at any scale position, depending on the resistance of the connected system and the saturation of the filter.

When adjusting the knob (9), work clockwise to minimize the risk of false alarms. Fast adjustments could trigger an alarm. The alarm will be reset after 3 seconds or if the unit is powered off (and on) again.

The suction power (setpoint) can be adjusted using the knob (9). The unit will automatically adjust the motor power to maintain the desired suction and airflow, even as the filter gets saturated.

Before setting the suction power, ensure the hose is in the desired working position and that all connections are correctly fitted.

Suction settings

	Hose length (m)	Set point
Nozzle	2.5	N1
Nozzle	5.0	N2
Nozzle	15.0	N3
On-Torch	2.5	T1-T8

4.4.1 Using the unit with a Nozzle (N1-N3)

Adjust the knob (9) using the suction settings table above to find the recommended setpoint, N1-N3¹⁾, depending on the hose length. For hose lengths over 2.5 meters, it may be possible to adjust the knob (9) slightly counterclockwise and still maintain adequate airflow, but with a reduced capturing distance.

¹⁾ Other nozzles than TM80/200 or other hoses than 50 mm, may require other settings.

4.4.2 Using the unit with a fume extraction torch (T1-T8)

Each fume extraction torch requires a specific airflow, as specified by the torch manufacturer, to ensure adequate extraction. Too high extraction can compromise weld integrity.

- 1) Measure the flow at the nozzle according to the instructions supplied by the torch manufacturer.
- 2) Adjust the knob (9) until the desired flow is achieved to ensure the correct extraction of fumes. For most torches, extraction will be correct using settings T1 to T8. However, in certain cases, N1-N3 may provide adequate extraction.
- 3) Repeat the process regularly according to the manufacturer's instructions or when welding conditions change.

Ensuring the correct flow is always the responsibility of the user.

4.5 Status lights, Warnings and Alarms

Green light (13), fixed	Indicates that the unit is operational, the motor is running, and the status is OK. The light turns off when an alarm is active.
Green light (13), flashing	Indicates that the unit is set to Auto mode but is on standby awaiting a run signal from the sensor clamp.
Orange light (12), slow flashing and green light (13) fixed	Indicates that the filter is approximately 85% full at the current setpoint. Green light (13) is still on since there is no malfunction/alarm.
Orange light (12), fast flashing and green light (13) off	Continuously flashing – indicates that the unit is not maintaining the desired pressure set by the knob (9)

If the alarm is activated, terminate welding operations immediately and refer Troubleshooting section for the corrective action.

5 MAINTENANCE

**WARNING!**

The mains supply must be disconnected during cleaning and maintenance.

**CAUTION!**

Only persons with the appropriate electrical knowledge (authorised personnel) may remove the safety plates.

**CAUTION!**

The product is covered by manufacturer's warranty. Any attempt to carry out repair work by non-authorised service centers or personnel will invalidate the warranty.

**NOTE!**

Regular maintenance is important for safe and reliable operation.

**NOTE!**

Perform maintenance more often during severe dusty conditions.

Before each use - make sure that:

- Product and cables are not damaged.

5.1 Cleaning the filter

A new filter must be fitted when the orange light is flashing continuously and suction cannot be maintained. See section "*Status lights, Warnings and Alarms*", page 13.

- 1) Wait 10 minutes after welding to ensure no glowing embers remain in the coarse separator (5).
- 2) Remove the suction hose (3).

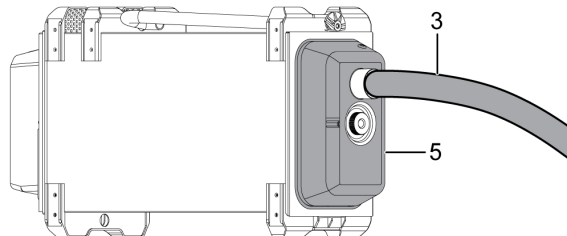

- 3) Turn the handle (4) down to lock the coarse separator.

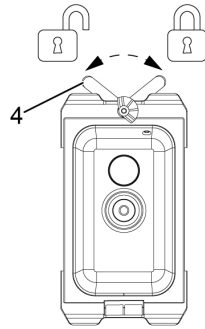

- 4) Set the main switch (1) to ON to turn on in manual mode at the highest setting.

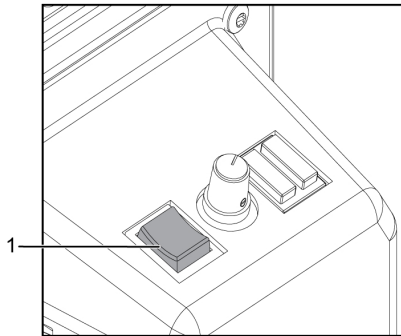

- 5) Turn the unit vertical so the inlet is facing up, then shake and tap it to allow the dust in the coarse separator to be sucked into the filter. Position the filter inlet (10) just behind the coarse separator inlet (9).

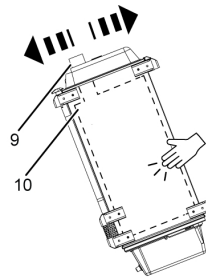

- 6) Set the mains switch (1) to OFF.

- 7) Loosen the filter indicator hose (2).

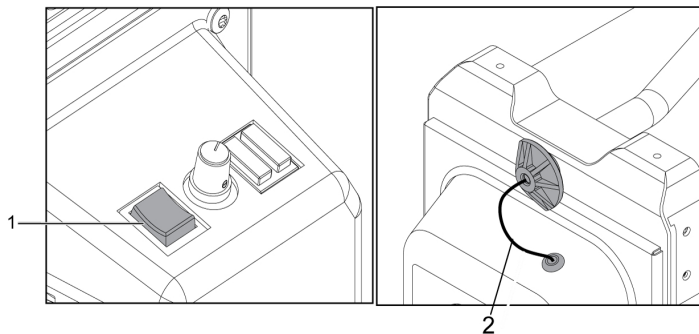

8) Turn the handle (4) to unlock and remove the coarse separator.

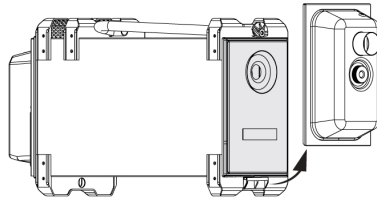

9) Pull out and dispose of the old filter (6). Place it in a plastic bag.

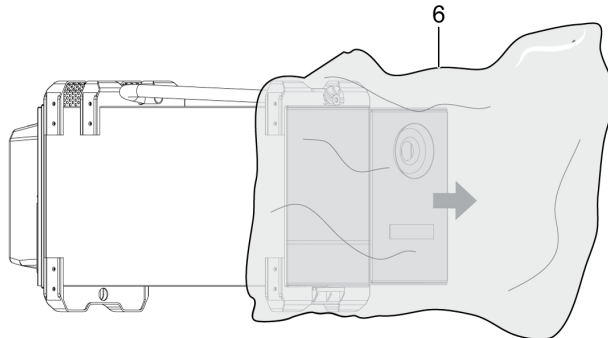

10) Tie the bag tightly.

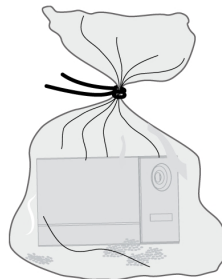

11) Insert a new filter and reassemble in the reverse order and make sure filter indicator hose (2) is properly connected.

5.2 Opening the coarse separator



WARNING!

Always take extreme precautions to avoid exposure and spread of dust when opening the coarse separator.

Always open the coarse separator inside a plastic bag or in a fume cupboard as the two halves can stick together and cause dust when they come apart.

Always wipe the coarse separator clean after it has been opened. If the coarse separator cannot be properly cleaned, it should be disposed of.

Normally there is no need to open the coarse separator but might be necessary when removing a clog or replacing the optional metal filter. Refer to "*Cleaning the filter*", page 14.

- 1) Place the coarse separator (5) in a plastic bag (9) or a fume cupboard. Unscrew the locking screw (7) and remove the outer part of the coarse separator.

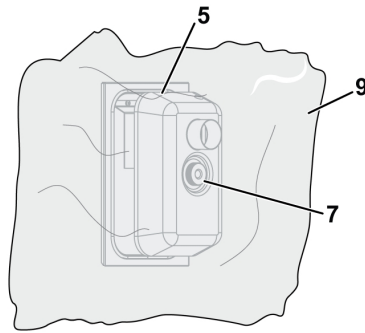

- 2) Empty the coarse separator and tie the bag tightly.
- 3) Check the rubber seal (8) around the coarse separator (5) for any signs of damage.

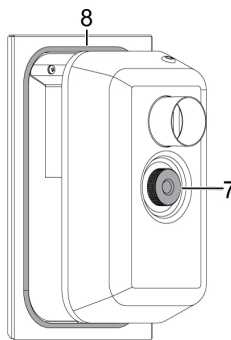

- 4) Reassemble the coarse separator (5) by putting the edge in the bottom groove (11). Lock with the locking screw (7) and the handle (4).

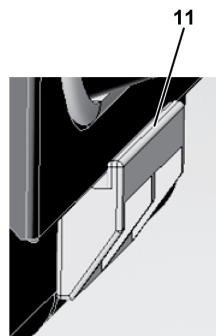

NOTE!

The coarse separator (5) is partly locked when the handle (4) is in an upright position, and fully locked when it is turned down.

6 TROUBLESHOOTING

Perform these checks and inspections before sending for an authorised service technician.

Check that the mains voltage is disconnected before starting any type of repair action.

Type of fault	Corrective action
The alarm is activated	Check that whether the setpoint is changed using the knob and the unit is still calibrating itself to reach the desired pressure (when the setpoint is changed the alarm may either be triggered or released).
	Check that the cables are correctly connected.
	Check that the hose or nozzle is not clogged or damaged.
	Check that the filter is clogged, damaged or bypassed.
	Check that the filter is not saturated to maintain the required suction and thereby requires changing as soon as possible.
	Check that unit cannot reach the desired pressure as the knob (9) is set too far clockwise in relation to the resistance in the system.

7 ORDERING SPARE PARTS



CAUTION!

Repair and electrical work should be performed by an authorised ESAB service technician.
Use only ESAB original spare and wear parts.

Carry Vac 3 is designed and tested in accordance with the international and European standards **EN ISO 21904-1, EN ISO 12100, EN ISO 20607, EN 61000-6-2, EN 61000-6-4, EN 61000-3-3** and **EN 60204-1**. On completion of service or repair work, it is the responsibility of the person(s) performing the work to ensure that the product still complies with the requirements of the above standards.

Spare parts and wear parts can be ordered through your nearest ESAB dealer, see [esab.com](https://www.esab.com). When ordering, please state product type, serial number, designation and spare part number in accordance with the spare parts list. This facilitates dispatch and ensures correct delivery.

APPENDIX

WIRING DIAGRAM

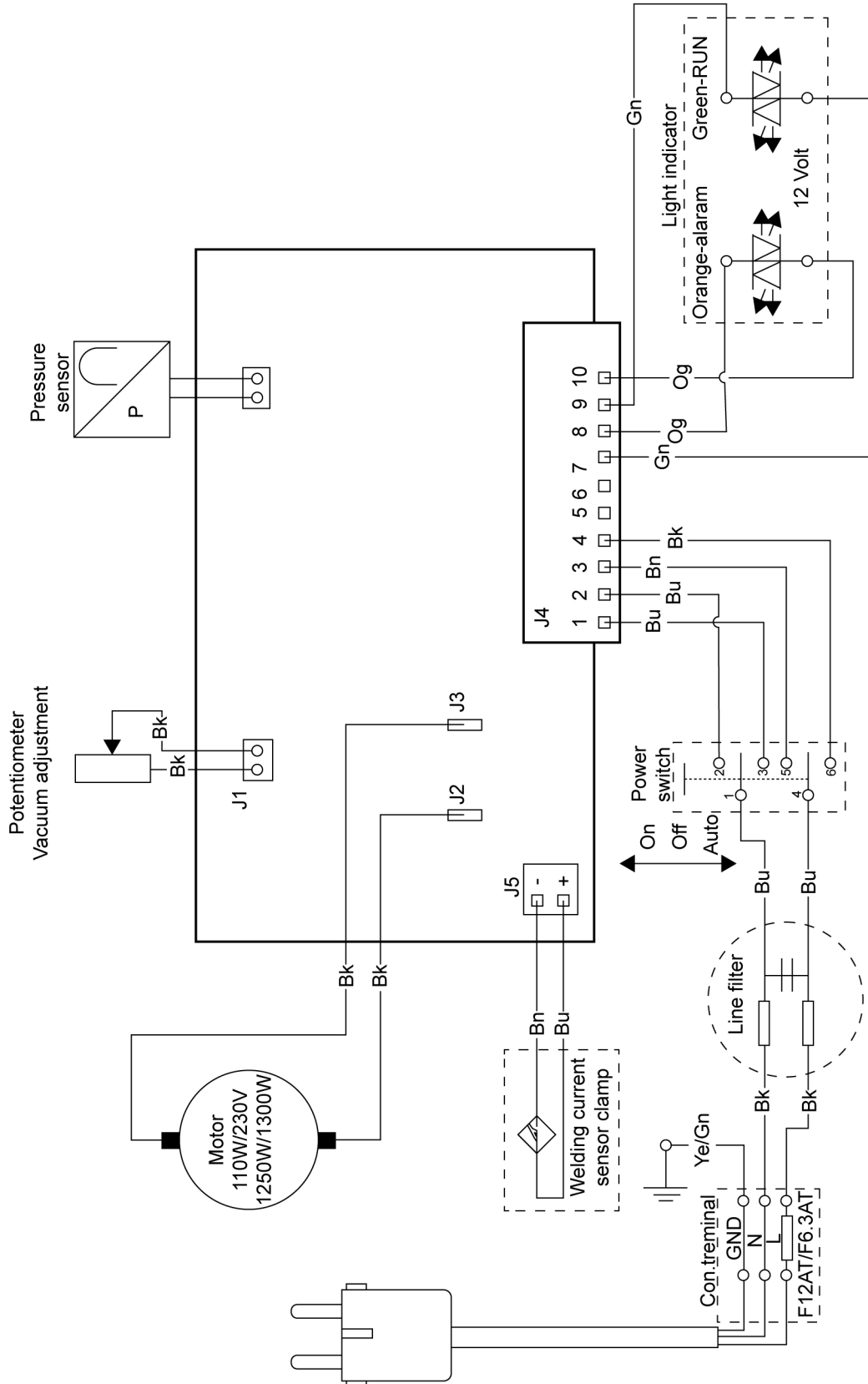

ORDERING NUMBERS

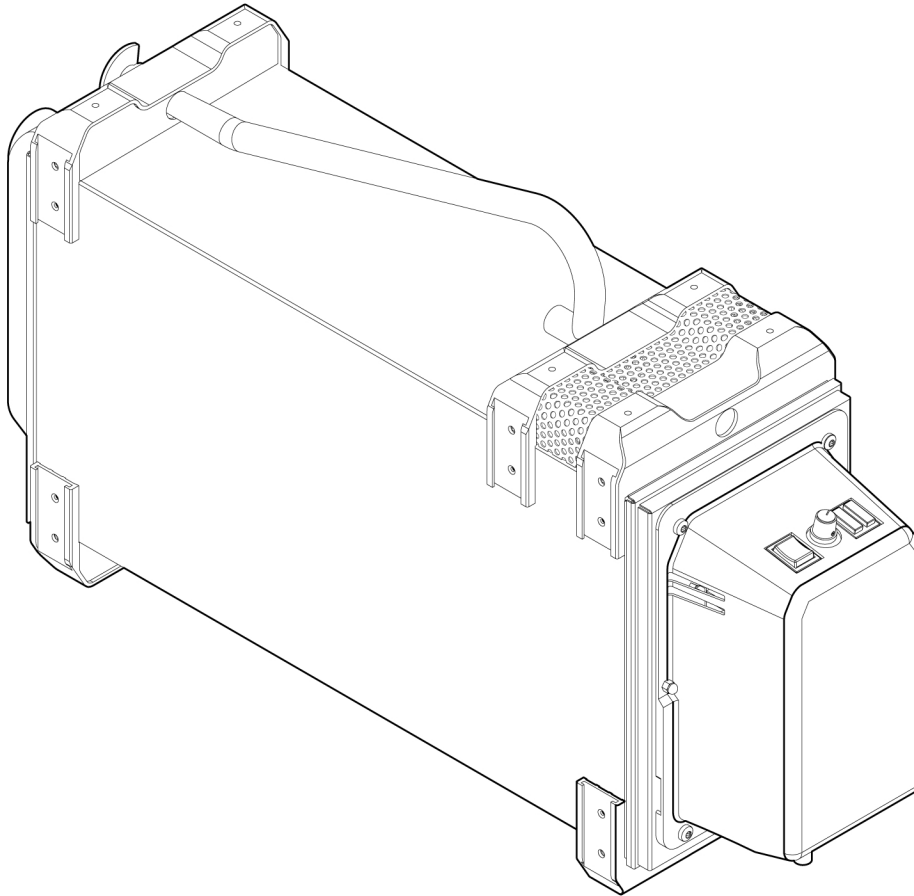

Ordering number	Denomination	Notes
0700 003 890	CarryVac 3	220-240V Euro
0700 003 891	CarryVac 3	110-120V UK
0700 003 892	CarryVac 3	110-120V US
0700 003 893	CarryVac 3	220-240V Euro hose connection
0463 843 *	Instruction manual	CarryVac 3

The three last digits in the document number of the manual show the version of the manual. Therefore they are replaced with * here. Make sure to use a manual with a serial number or software version that corresponds with the product, see the front page of the manual.

Technical documentation is available on the Internet at: www.esab.com

SPARE PARTS LIST

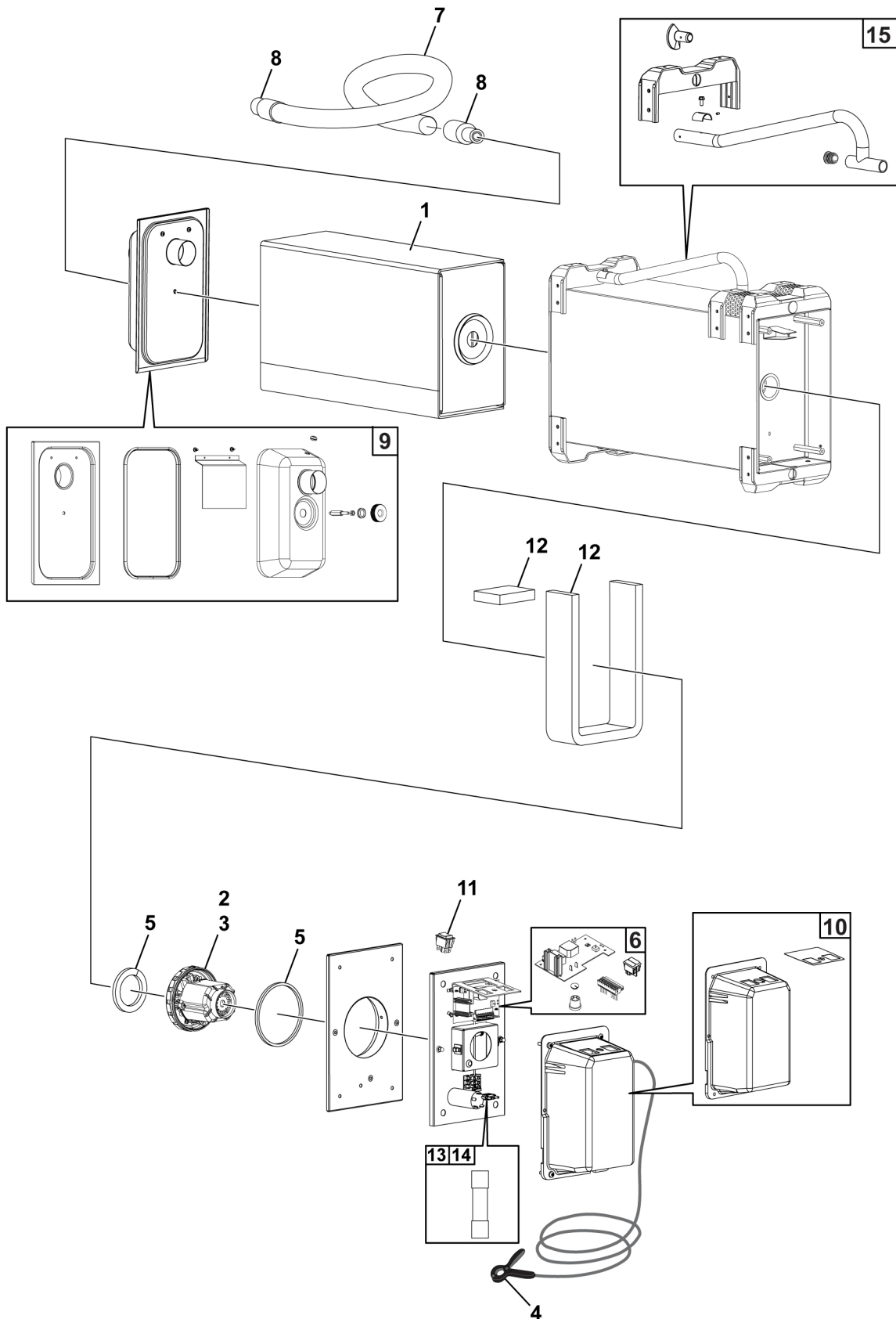

APPENDIX

Item	Qty	Ordering no.	Denomination	Notes
1	1	0700 003 903	Filter nano disposable	
2	1	0700 003 904	Motor 1250 W 110 V	
3	1	0700 003 905	Motor 1300 W 230 V	
4	1	0700 003 091	Sensor clamp	
5	1	0700 003 906	Kit motor gaskets	
6	1	0700 003 907	Control unit	
7	1	0700 003 908	Hose superflex crushproof Ø50	2.5 m
8	1	0700 003 909	Hose connection M50 Ø50	
9	1	0700 003 910	Pre-separator	
10	1	0700 003 911	Motor cover w.overlay	
11	1	0464 663 106	Switch 3-pos.	
12	1	0700 003 912	Kit sound sealing	
13	1	0700 003 913	Fuse 5×20 mm 6.3AT	10 pcs
14	1	0700 003 914	Fuse 5×20 mm 12AT	10 pcs
15	1	0464 663 078	Handle kit	

REPLACING THE CIRCUIT BOARD

- 1) Disconnect the mains cable.

**WARNING!**

Be aware of electric shock.

- 2) Loosen the set screw (1) using a 2 mm flat screwdriver. Remove the knob for suction power (2).
- 3) Remove the motor cover (3).
- 4) Remove the potentiometer (4).

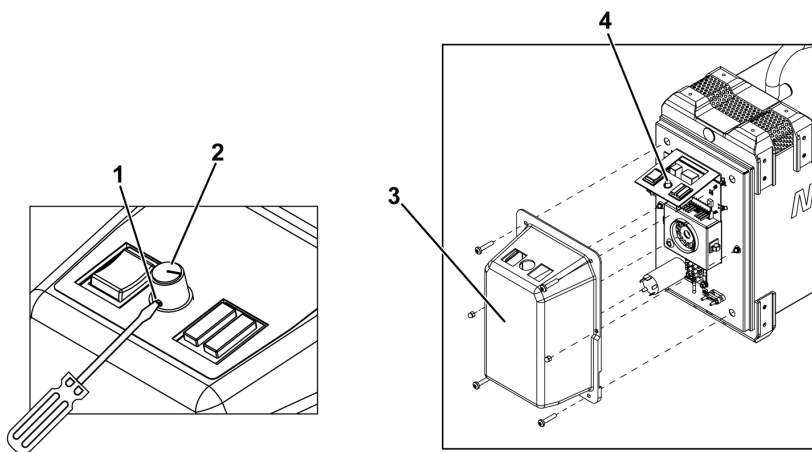

- 5) Cut the cable tie (5) and the pressure sensor hose (6). The pressure sensor hose is reused on the new board.

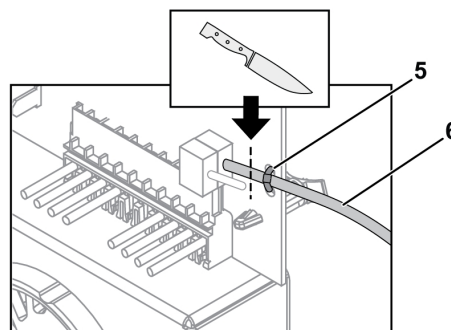

- 6) Release the circuit board (7). Lift the circuit board upwards for best access.
- 7) Pull out the connector (8) from the circuit board.

8) Disconnect the motor cables (9) and the power supply cables (10).

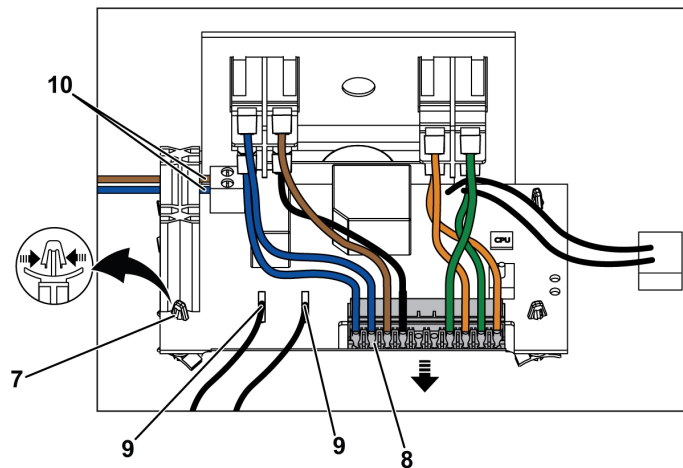

9) Mount the pressure sensor hose (11) on the new circuit board. Secure the pressure sensor hose with the supplied cable tie (12). The pressure sensor hose is connected to the lower port on the pressure sensors. The upper one must be open.

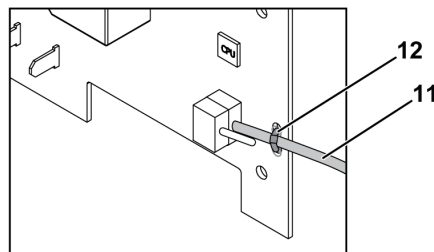

10) Refit the connector (8).

11) Reconnect the power supply cables (10).

i NOTE!
Brown power supply cable on negative pole. Blue power supply cable on positive pole.

12) Reconnect the motor cables (9). The motor cables are not polarized.

13) Mount the new circuit card in the snap-in spacers (7).

14) Refit the potentiometer (4).

15) Mount the motor cover (3).

16) Turn the potentiometer (4) to mechanical max and refit the knob for suction power (2) to align with T8 position. Secure it with the set screw (1).

REPLACING THE MOTOR

- 1) Disconnect the mains cable.

**WARNING!**

Be aware of electric shock.

- 2) Remove the four screws (1) using a T30 Torx screwdriver. Loosen the motor assembly (2).
- 3) Disconnect the earth cable (3).

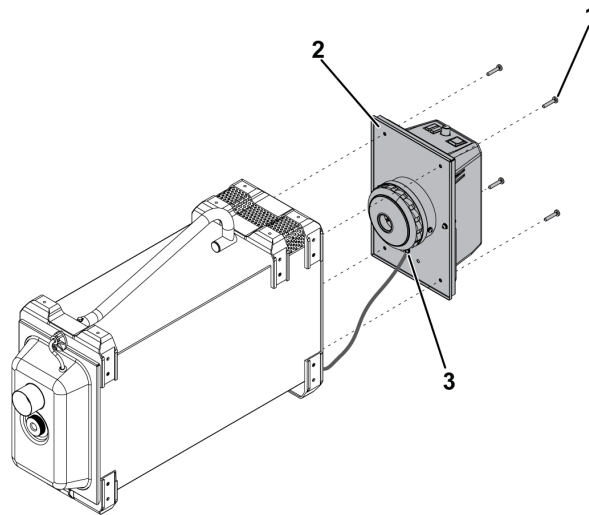

- 4) Remove the two screws (4) and the nut washers (5) using a T25 Torx screwdriver. Lift out the motor (6). Note how the motor is oriented. Disconnect the two motor cables (7).

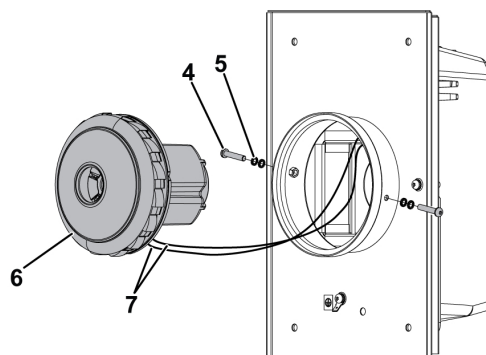

- 5) Connect the new motor to the motor cables (7). Mount the motor in the same position as the old one.

6) Mount the two screws (4). Use two lock washers (5) on each side.



NOTE!

Max. 2 Nm tightening torque.

7) Reconnect the earth cable (3).

8) Mount the motor assembly (2) with the four screws (1).

REPLACING THE SPARK FILTER

- 1) Turn the handle (1) to unlock the separator (2).
- 2) Loosen the pressure sensor hose (3).
- 3) Remove and position the separator (2) on a work bench.
- 4) Loosen the knob (4) to open the separator.

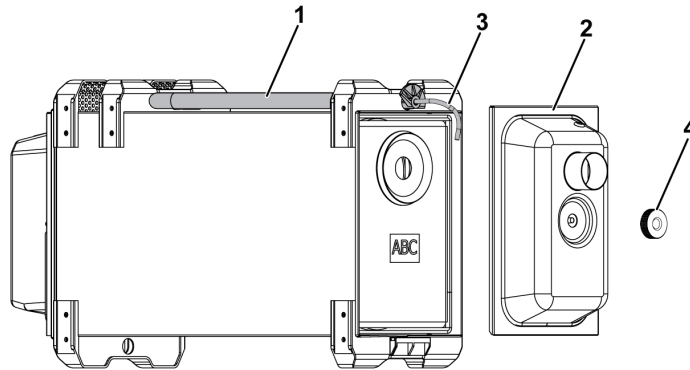

- 5) Unscrew the two screws (5) holding the inner coarse separator screen (6).

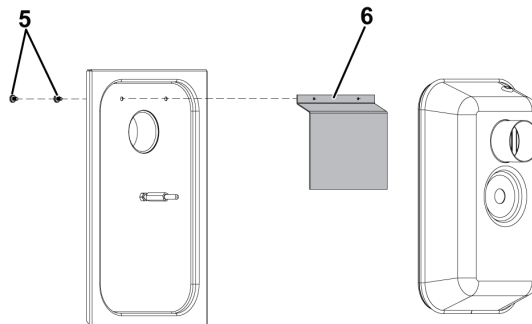

- 6) Fit the enclosed plugs (7) into the two holes in the inner separator plate (8). Mount the plugs on the inside against the housing.

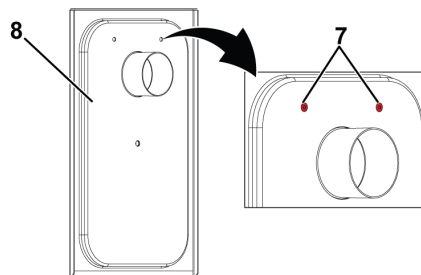

- 7) Mount the spark filter (9) in the frame (10). Mount the screw (11).

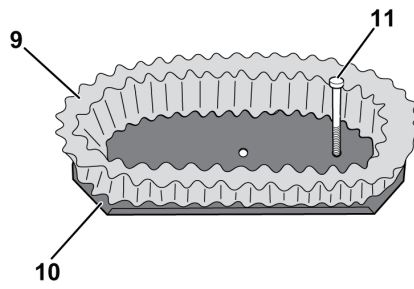

- 8) Mount the complete spark filter to the separator plate. Fasten with the supplied M6 nut (12).

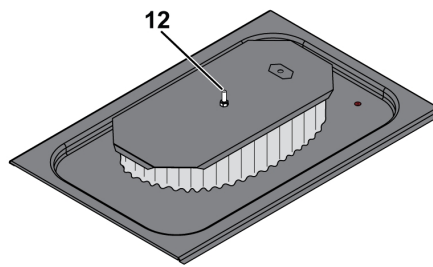

- 9) Refit the separator cover. Tighten the knob (4) and mount the separator (2). Turn the handle (1) to secure the separator.

ACCESSORIES

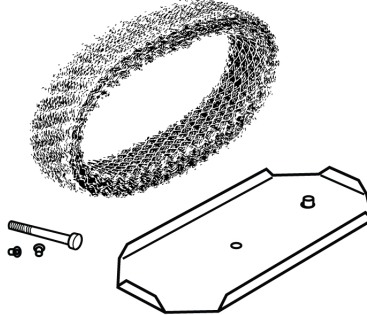
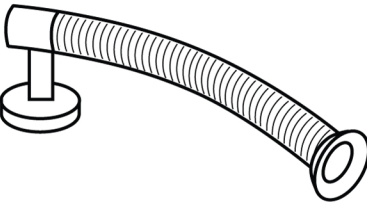
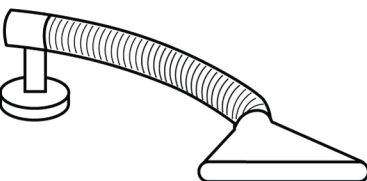
0700 003 014	Metal filter	
0468 455 002	Metal filter, complete	
0700 003 221	Nozzle TM 80, length 500mm, ø80mm	
0700 003 222	Nozzle TM-200 funnel	

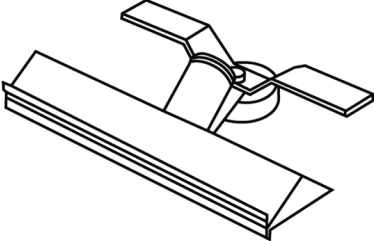
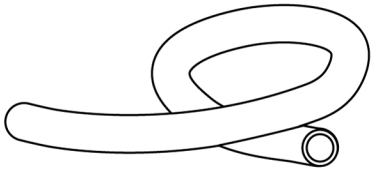
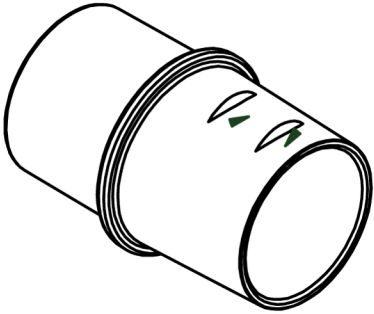
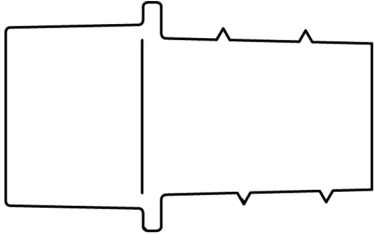
0700 003 223	Nozzle flange PM-300	
Hose superflex crushproof Ø50		
0700 003 917	5 m	
0700 003 918	15 m	
0700 003 919	Hose connection M50 Ø50	
0464 663 043	Fume torch adaptor	



A WORLD OF PRODUCTS AND SOLUTIONS.



For contact information visit <http://esab.com>

ESAB AB, Lindholmsallén 9, Box 8004, 402 77 Gothenburg, Sweden, Phone +46 (0) 31 50 90 00

manuals.esab.com

