

Pipe feeder base unit and extension unit

The pipe feeder accurately feeds long and heavy pipes into GF and RA machines. Very sturdy and stable design with powder-coated frames and stainless steel rollers.

Advantages:

- Extremely stable and sturdy
- Fast adjustment of dimensions
- Centerline of tubes and pipes adjust easily in seconds
- Steel frame coated for maintenancefree finish
- Rollers made of stainless steel
- Extension of the Pipe Feeder possible with Extension Unit
- Saves time and money
- No contamination
- Perfect for all kinds of steel

Base unit:

Fits all pipe cutting and beveling machines in the GF and RA series from Orbitalum Tools (except the RA 21 S and GF 20 AVM. RA 2, GFX 3.0, PS 4.5 and PS 6.6 on request). The machines can be directly mounted onto the base plate of the pipe feeder base unit, without further parts. The machines can be easily adjusted to the required cutting dimension using the handwheel-operated mechanical height adjustment. The machine is securely fastened to the base plate.



Pipe feeder base unit

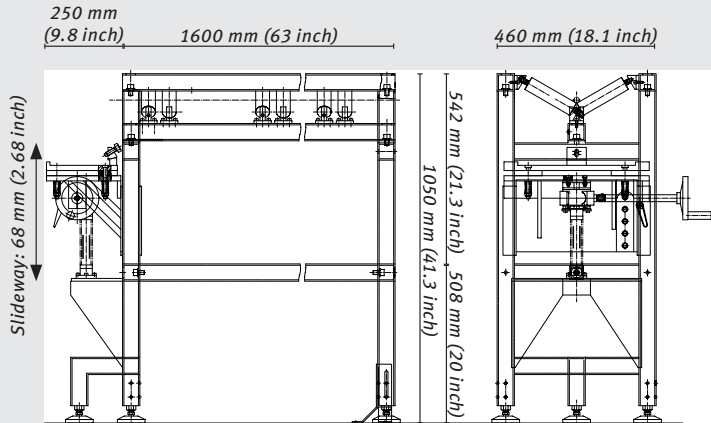

Extension unit:

To extend the the base unit, can be used singularly or in multiples, easily bolted together.



Pipe feeder extension unit

